

TOPTUL®

3200 B.P.M Air Hammer

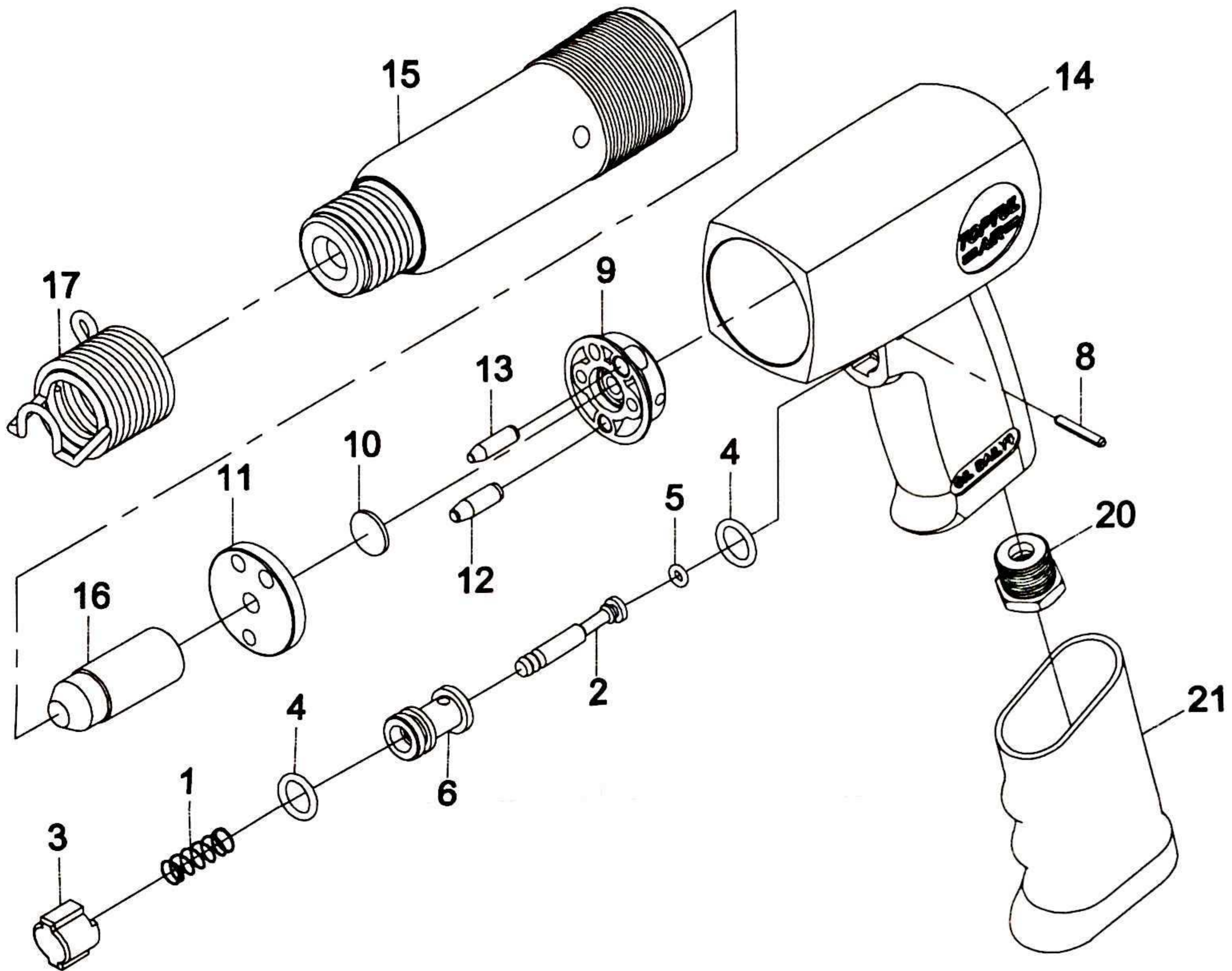

KAHA3217

Specification : Medium-Barrel Air Hammer	
Stroke Speed : 3200 BPM	Air Inlet : 1/4" PT
Piston Stroke : 2-5/8"	Min. Air Hose : 3/8" I.D.
Air Consumption : 10 CFM	Air Pressure : 90 PSI

Index No.	Parts No.	Description	QTY	Index No.	Parts No.	Description	QTY
1	KAEK0010	Valve Spring	1	11	KAEK0110	Case Valve	1
2	KAEK0020	Throttle Valve	1	12	KAEK0120	Dowel Valve Vase (L)	1
3	KAEK0030	Button Throttle	1	13	KAEK0130	Dowel Valve Vase (S)	1
4	KAEK0040	O-Ring (d11 x w2.4) (P12)	2	14	KAEK0140	Handle	1
5	KAEK0050	O-Ring (d3.8 x w1.9) (P4)	1	15	KAEK0150	Cylinder (M)-Hex(10mm)	1
6	KAEK0060	Bushing Valve	1	16	KAEK0160	Piston (M)	1
8	KAEK0080	Spring Pin (φ3x20L)	1	17	KAEK017A	Retainer Zip Change	1
9	KAEK0090	Lid Valve Case	1	20	KAEK0200	Air Inlet (1/4" PT)	1
10	KAEK0100	Disc Valve	1	21	KAEK0210	Grip	1

2011.06