

VERTICAL SANDBLAST CABINET



**READ ALL INSTRUCTIONS
BEFORE OPERATING THE SANDBLASTER**

SAVE THIS MANUAL

You will need this manual for the safety instructions, assembly and operating instructions and parts list. Put it in a safe dry place for future reference.

**READ ALL INSTRUCTIONS
BEFORE OPERATING THE
SANDBLASTER**

SPECIFICATIONS

CHARACTERISTIC	VALUE
Overall dimensions	860MM x 550MM x 1390MM
Gross Weight/Net Weight	51KGS/48KGS
Electrical Requirements of light	115V/230V
Maximum operation pressure	125PSI

SAFETY WARNING & CAUTIONS

1. KEEP WORK AREA CLEAN. CLUTTERED AREA INVITE INJURIES.
2. KEEP CHILDREN AWAY. All children should be kept away from the work area. Don't let them handle tool.
3. WEAR GOGGLES or SAFETY GLASSES DURING OPERATION. GLASS LENS IS 5MM TEMPERED, BUT STILL BREAK. Replace only with Tempered or Safety Glass. Size: 610MMx3.4MM.
4. USE GROUNDED RECEPTACLE ONLY for electrical hookup. Require 110/230 volts to operate vacuum.
5. REPLACE GLOVES. Cabinet gloves do wear. Replace as necessary.
6. CLOSE AND LATCH DOOR DURING OPERATION.
7. DISCONNECT INCOMING AIR LINE when adding abrasive, or when servicing hoses, power gun, or other components.
8. MAXIMUM OPERATING PRESSURE-125PSI.

ASSEMBLY

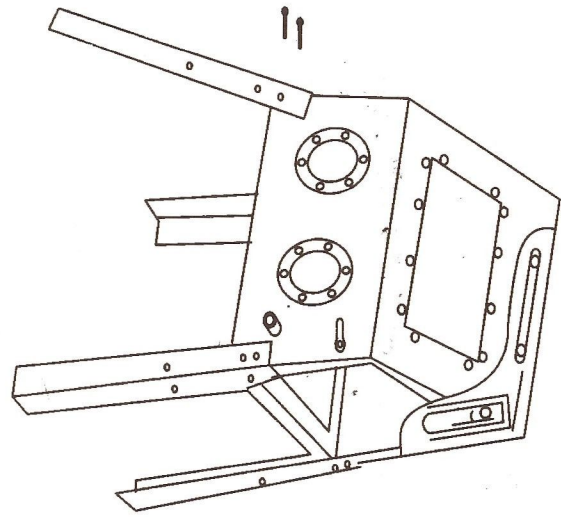

LEG INSTALLATION

1. Place cabinet on its back on a table or Bench.
2. Remove M6 x 12 bolts,nuts lock washer,& washers from bolt packet.
3. insert M6 x 12 bolt through leg & into cabinet.
4. Place M6 washer and M6 lock washer over bolt and M6 hex nut. Hand tighten.
5. Repeat above for remaining three legs.

FUNNEL, NET AND FRAME

FOUNDATION OF NET INSTALLATION

1. Stand cabinet upright.
2. Place net on funnel.
3. Remove four M6 x 20 bolts and washers and four hex nuts from bolt package.
4. Insert four M6 x 20 bolts and washers through holes in funnel frame foundation into cabinet. Place washers and nuts over bolts and tighten.

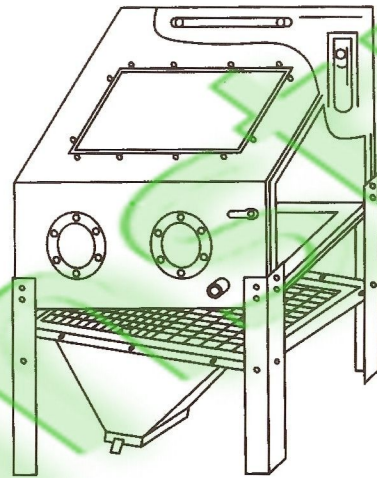

SHELF INSTALLATION

1. Stand cabinet upright.
2. Remove eight M6 x 12 bolts,16 washers and eight hex nuts from bolt package.
3. Insert eight M6 x 12 bolts and washers through holes in leg and shelf,place washers and M6 lock washers and nuts over bolts and tighten.
4. Tighten leg bolts and level cabinet.

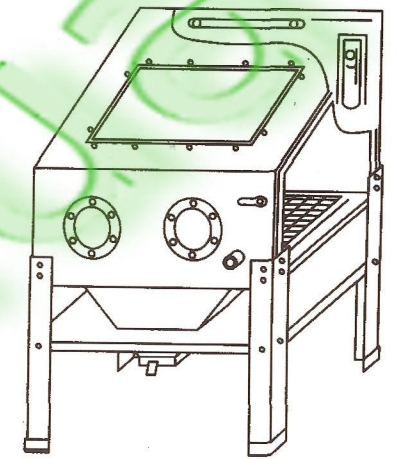

CABINET LEG TRIM MOULDING

Enclosed are four trim Mouldings for bottom of Cabinet legs. They may be pushed in place,without tools.

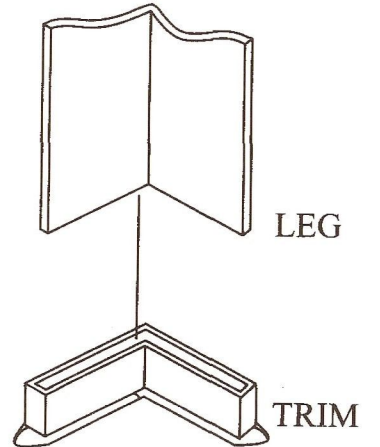

AIR REQUIREMENTS:

For best results, we recommend a good 5 HP air compressor. A small nozzle/air jet combo is use with a 3 HP air compressor.

HOW IT WORKS

Your shop air hose enters front opening of cabinet and is connected to the air inlet of Power Gun.Bottom handle of gun has 1/4" pipe threads which will fit most air hose. Cabinet pickup tube leads to clear siphon hose which connects to gun head assembly.

Pour glass beads or other abrasive into cabinet hopper through the side loading door. Place parts to be blasted in cabinet and close door. With hands in cabinet gloves aim power gun at object. pull trigger and let our unique siphon recycling system do the rest. Rust, paint and scale are quickly removed, leaving the original metal clean and intact. Abrasive drops to the bottom of cabinet for continual recycling each time power gun is activated.

Abrasive can be re-used until it eventually breaks down or becomes dusty. To discard worn abrasive simply place empty box under spring loaded trap door. Add more abrasive and resume blasting.

Your shop vac connects to vacuum ferrule is necessary to remove the dust created in blasting. When using a shop vacuum, be sure to install the paper filter over the standard filter. Otherwise, abrasive could work its way into the vacuum motor, causing bearing failure.

At right front of cabinet is an opening for your air hose from your compressor. An ordinary 3/8" ID air hose should fit through this opening. connect your air hose should fit through this opening. Connect your air hose to bottom handle of power gun by screwing into place(use teflon tape or pipe compound-do not over tighten). Close door and pull trigger a few times to test operation. You are now ready to add abrasive.

Add suitable abrasive by pouring through side door opening and allowing it to fill funnel area. Do not over fill (1/2 full below work area screen is best).

NOTE: use a fine grade of abrasive to prevent clogging. We recommend straining through a double layer of ordinary window screen. If it passes through the screen, it will pass through the nozzle. YOU ARE READY TO START BLASTING.

Parts List

#	Description	Qty.	#	Description	Qty.
1	Cabinet	1	23	Air adapter nut	1
2	Guard ring of intake vent	1	24	Light low voltage	1
3	Cover of behind intake vent	1	25	Light clamp	2
4	Hinge	1	26	Steel screen	1
5	Plastic door	1	27	Sealant cotton	1
6	Metal liner	1	28	Cabinet funnel	1
7	Gloves, pair	1	29	Abrasive suction pipe	1
8	Clamp for glove	2	30	Abrasive removal cover	1
9	Mounting ring glove	2	31	Cover lock	1
10	Rubber insert	2	32	Shelf	1
11	Suction flange	1	33	Legs	4
12	Cover of suction flange	1	34	Feet	4
13	Switch	1	35	Abrasive intake hose	1
14	Switch box low voltage	1	36	Abrasive gun	1
15	Plug low voltage	1	37	Nozzle adapter nut	1
16	Adaptor	1	38	Nozzle	4
17	Plastic frame	1	39	Clamp(φ 20)	1
18	Plexiglass	1	40	Air hose adapter	2
19	Glass	1	41	Clamp(φ 10- φ 13)	2
20	Protection film	1	42	Air hose	1
21	Sealant cotton	1	43	Flat washer	2
22	Knob	1			

